



VORTEX

ALL ABOUT OPTICS

Your Guide to Understanding and Selecting
Binoculars, Spotting Scopes, and Riflescopes.





ALL ABOUT OPTICS

For hundreds of years we've used optics, such as binoculars and spotting scopes, to enhance our vision and see our world in new and exciting ways. Vortex Optics offers multi-purpose instruments that expand our ability to see, and are useful for activities like:

- **Hunting**
- **Bird watching**
- **General nature observation**
- **Hiking and camping**
- **Astronomical observation**
- **Sporting events and concerts**

New to this edition of **All About Optics** is a section on riflescopes for hunters, helping you understand how to choose, mount, and sight in a riflescope.

Table of Contents

The Basics of Optics _____	3—10
Binoculars _____	11—21
Spotting Scopes _____	22—24
Riflescopes _____	25—34

THE BASICS OF OPTICS

Understanding the following specifications and definitions will aid you in selecting optics that will function best for you when out in the field.

Eye Relief

The term eye relief refers to the distance (measured in millimeters) between the ocular lens and where the



Long eye relief for better views.

image comes to focus and the entire field of view can be viewed. Binoculars and spotting scopes offering at least 15mm are most important for:

- **People who must wear eyeglasses or sunglasses** while looking through binoculars.
- **Anyone** planning to view through binoculars for long stretches of time.

Close Focus

This is the minimum distance to which you can focus a binocular or spotting scope on your subject.

Field of View

Another important number to understand is the field of view. This is the distance from left to right that you can see when looking through the optics. The field of view can be measured either in linear feet at a distance of 1000 yards or in angular degrees. (**One degree equals 52.5 feet**).

Note: When comparing binoculars with the same size objective lenses, higher magnifications will have a narrower field of view.

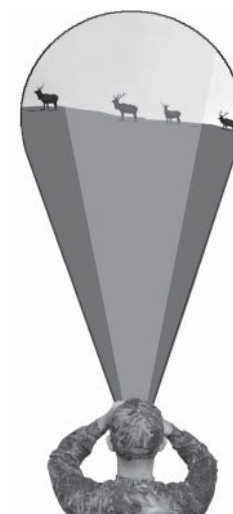



Weatherproofing

Waterproof / fog proof binoculars are sealed with O-rings to inhibit moisture, dust, and debris. The inside of the binocular is then purged of atmospheric air and filled with an inert gas that has no moisture content. This will prevent internal fogging from high humidity or altitude changes.

- **Nitrogen gas** is most commonly used.
- **Argon gas** is used in select optics because it maintains a higher level of anti-fogging protection over a longer time.

Exit Pupil

This is the beam of light that exits each eyepiece and enters the user's eyes. The larger the exit pupil, the brighter the image will appear—especially under low light conditions.



$$\text{Exit Pupil} = \frac{\text{Objective Lens}}{\text{Magnification}}$$

Warranty

A manufacturer's warranty ought to be considered a feature of the binocular—especially if you use the optics outdoors where anything can happen.

- **Most manufacturers** offer a warranty limited only to initial defects with no protection from accidental damage or regular wear and tear.
 - **Progressive warranties** cover optics in any situation, no matter what happens or who is at fault.
- The Vortex VIP warranty** is an unconditional, unlimited warranty that offers the ultimate in customer service and protection for your optics.

Components of an Optical System

The optical design of binoculars and spotting scopes is comprised of three main components: the objective lenses, prisms, and ocular lenses.

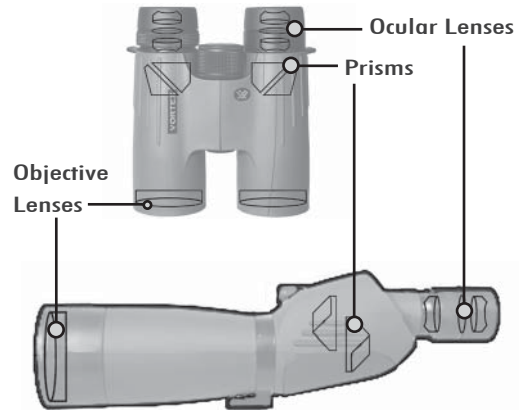

Objective Lenses Gather Light

The larger the objective lens, the more light it can gather and transmit through the optical system to the user's eyes. Increased light means brighter views.

Ocular Lenses Magnify.

The ocular lenses magnify the image transmitted by the objective lenses. Many of the important optical specifications (such as field of view, eye relief, etc.) are primarily determined by the design of the ocular lenses. The overall quality is affected by the care taken in the manufacturing and polishing of the glass along with the quality and quantity of anti-reflective coatings employed.

Prisms Do Double Duty.

The prisms of an optical system have two jobs.

- **Prisms correct the image** so it appears properly oriented—otherwise the image would be presented upside-down and backwards to the user.
- **Prisms shorten the binocular length** because light bouncing through a prism system can follow a short path.



What Determines Image Quality?

There are differences in the quality of the optical glass and anti-reflective lens coatings. When comparing optics of similar quality, keep in mind that a larger exit pupil will deliver brighter views—especially in low light.

Optical Glass

Optical glass quality will make a difference in how bright, sharp, and colorful the view will be. The more sophisticated the glass and techniques employed in the optical design, the better the images. Quality optics use dense optical glass that is painstakingly designed, shaped, and polished to eliminate flaws.

- **XD high density glass** in select Vortex binoculars delivers the absolute highest quality images.
- **ED glass** in spotting scopes with very large objective lenses achieves the highest possible image resolution, contrast, and color fidelity.

Anti-Reflective Lens Coatings

When you look at an optical lens, you'll notice the anti-reflective coatings as tints in the glass (usually purplish or greenish in color). Metallic compounds, including Magnesium Fluoride, are vaporized and applied to the optical glass in extremely thin layers that eliminate internal reflections and light scattering, and also reduce glare.

Why Anti-Reflective Coatings are Needed

The type and number of coatings applied to the lenses in a binocular or spotting scope make a significant difference in how brilliant and crisp the views will be. The application of more coatings results in an increase of light transmission, resolution, contrast, and color fidelity.

Each time light strikes an uncoated glass surface 4–5 percent of the light is reflected.

Without coatings, almost 50 percent of the light could be lost as it passes through the multiple air-to-glass surfaces of a standard binocular or spotting scope.

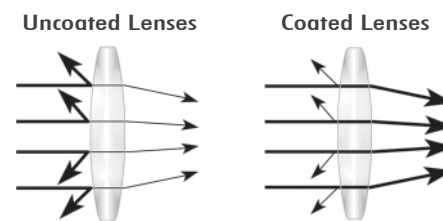

Levels of Anti-Reflective Coating

- **Coated optics** have one or more surfaces coated with one or more anti-reflective coating films.
- **Multi-coated optics** have one or more surfaces coated with multiple anti-reflective coating films.
- **Fully-coated optics** have all air-to-glass surfaces coated with an anti-reflective coating film.
- **Fully multi-coated optics** have all air-to-glass surfaces coated with multiple anti-reflective coating films, and offer the highest image quality.

Other Important Optical Terms

Alignment or Collimation – All elements (lenses or prisms) are in line along the optical axis. The misalignment of elements results in diminished performance and can cause eye strain and fatigue.

Astigmatism – Because the lenses in a binocular or spotting scope usually have a curved shape, the light rays passing through the lens will not all converge on the same focal plane. If this physical reality isn't remedied in the overall optical design, images will either be in focus in the center area or at the edge—but not in both areas at the same time. Astigmatism cannot be eliminated completely, but it can be kept to a minimum. Avoid optics that exhibit too much astigmatism.

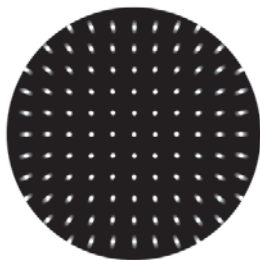

Center in Focus

Chromatic Aberrations – Diminished resolution and color fidelity display as green or purple fringing. This is the result of a physical reality of color. Different colors move at slightly different wavelengths and will have slightly different focal lengths when passing through optical glass. The XD and ED glass types reduce or eliminate this inherent problem of chromatic aberrations.

Contrast – This refers to differences in brightness between the light and dark areas of an image. Because we see much of the color spectrum, contrast also refers to differences in the dimensions of hue, saturation, brightness, or lightness. Optics with superior contrast transmit colors that appear very dense and well-saturated.

Distortion – This is the inability of an optical system to deliver an image that is a true-to-scale reproduction of an object. There are two types of distortion. In either case, the distortion is due to a poor or compromised optical design. Any binocular or scope that exhibits distortion should be avoided.

- **Barrel distortion:** Image bows outward and look bulged.
- **Pincushion distortion:** Image bends inward.

Light Transmission – This is the percentage of light that passes through the binocular, spotting scope, or riflescope to reach the user's eyes. Light transmission will be higher through more expensive optics than through modestly priced optics due to better optical designs, glass quality, and improved optical coatings.

Resolution – Essentially the same as image sharpness, resolution is the ability of the binocular to separate and distinguish thin lines with clarity.

Use a resolution chart to determine how well a binocular, spotting scope, or riflescope can resolve fine details. A resolution chart contains groups of lines set in a series with progressively smaller spacing—a design used to ascertain the limiting number of lines per millimeter that optics can resolve.

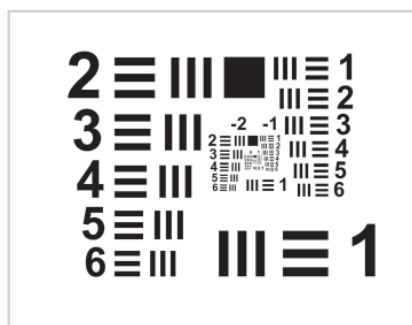



Sorry, But There Are No Perfect Optics.

Consider the trade-offs when selecting optics.

Objective Lens Size is the main trade-off to consider. Larger objective lenses deliver brighter images—especially under low light conditions. However, larger also means heavier and bulkier. Think about how much you want to carry!

Optical Glass weighs more as quality increases, making the binocular or spotting scope heavier. Vortex offsets the weight of the glass components by using rugged, yet lightweight, housing materials.

Higher Magnification is not always the best choice.

- **In binoculars:** It will have a shallower depth of field, greater chance of image shake, and diminished field of view.
- **In scopes:** It will greatly diminish the field of view and reduce image brightness.

Close Focus and Depth of Field are related. A binocular with a close focus will generally have a shallow depth of field.

BINOCULARS

What do the numbers mean?

Binoculars do the job of magnifying, clarifying, and presenting a more three-dimensional view of an image compared to the unaided eye. When you look at a pair of binoculars, you'll notice numbers like 8x42 (read as "eight by forty-two") printed on the binoculars.

Magnification

The first number (**8x**) refers to the magnification the binoculars provide, or how many times larger an object will appear.

Binoculars vary in magnification, but 8x and 10x are most common.



Higher magnification is not necessarily better.

As magnification increases, users may have trouble holding the binoculars steady, and an image will appear to shake. In addition, an increase in magnification generally causes a decrease in image brightness. 7x or 8x magnification is considered adequate for woodland settings, while 10x is preferred for viewing at greater distances.

Objective Lens Size

The second number (**42**) refers to the diameter of the objective lens in millimeters. Objective lenses vary in size from 15mm to 50mm and beyond.



The size of the

objective lens determines how much light the binoculars can receive and how bright the resulting images will be. The size of the objective lens also affects the size of a binocular.

Binocular Specification Considerations.

Why the Exit Pupil Matters

A larger exit pupil will deliver brighter images and is most important when viewing in low-light conditions. Note that a person's pupil can dilate from roughly 2mm to 8mm depending on the lighting situation and that person's age. For example:

- **In bright lighting** the pupil will dilate to about 2–3 mm.
- **At dawn or dusk** the pupil will dilate to about 4–5 mm.
- **In darker conditions**, the pupil will dilate to about 7–8 mm.

Exit Pupil of an 8x42 Binocular



Look for the exit pupil when holding the optics a short distance from your face.

Calculate the exit pupil of a binocular by dividing the objective lens by the magnification.

$$42 \div 8 = 5.25 \text{ mm Exit Pupil}$$

Let your observation habits determine the size that's right for you. If you use your binoculars only during the brightest light of day, then smaller objective lenses under 25 mm will do just fine. If you want the brightest possible image during near-dark conditions, you'll want to choose objective lenses in the 35 mm to 56 mm range.

Benefits of Long Eye Relief

An increasing number of binoculars not only have at least 15mm of eye relief, but also have multiple eyecup settings that allow for a custom fit.



Advantages of a Wide Field of View

A wide field of view has advantages when following fast-moving action and scanning dense habitats.

The Importance of Close Focus

Many binoculars will focus down to ten feet or less—a feature that is especially important for watching butterflies, insects, and birds.

How Size and Weight are Related

The greatest factor in determining the weight of a binocular is the size of the objective lens. The larger the lens, the heavier the binocular will be.

- **Compact binoculars** can weigh from a few ounces to under a pound.
- **Full-size binoculars** can weigh from twenty ounces to around two pounds.

The Value of Weatherproofing

Binoculars that effectively keep out the elements will inevitably last longer. For the utmost in protection, all Vortex binoculars are waterproof and fog proof.

How Prism Glass Affects Image Quality

The density of prism glass is an important factor that affects the ability of a binocular to deliver high-quality images. The care taken in grinding and polishing the prisms is also important.



Binocular Designs

The Roof Prism Design

Named for the roof-like appearance of the prisms, the roof prism binocular has objective lenses and eyepieces positioned in a straight line.

Roof prisms are appreciated for their durability and streamlined bodies.

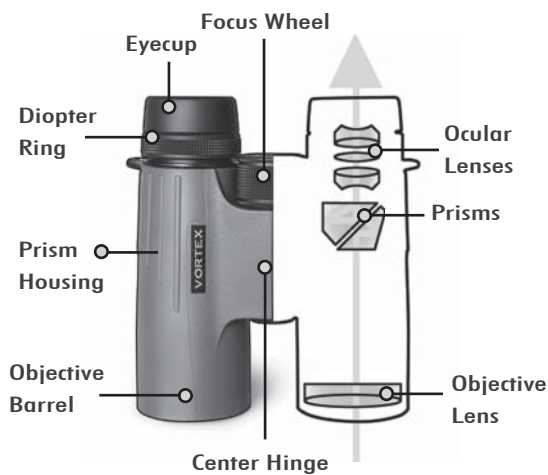

Phase correction is a set of coatings on the prism glass that keeps light in correct color phases. These coatings are only needed on roof prism binoculars to enhance the resolution, contrast, and color fidelity.

Glass type is not as great a factor with roof prisms as with Porro prisms. Fine quality in a complex prism comes with care in engineering and design.

The Porro Prism Design

Named after their Italian optical designer, Porro prism binoculars are characterized by the objective lenses being spaced wider apart than the eyepieces. The design shown here is the reverse Porro prism used in compact binoculars. It has eyepieces that are more widely spaced than the objectives.

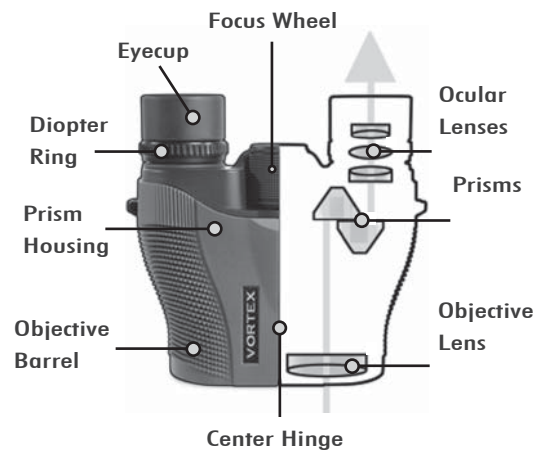

Porro prisms offer a rich depth of field, a wide field of view, and a three-dimensional image. Many people recognize the traditional binocular shape of a Porro prism by its offset barrels. This prism system delivers good quality at a reasonable cost.



How a Binocular Works

Regardless of the size and shape, all binoculars function in the same way.

1. Light enters and moves through the objective lenses of the binocular.
2. Light travels through prisms that correct the image orientation in all directions.
3. Light moves through eyepieces to magnify the image before it reaches a user's eyes.

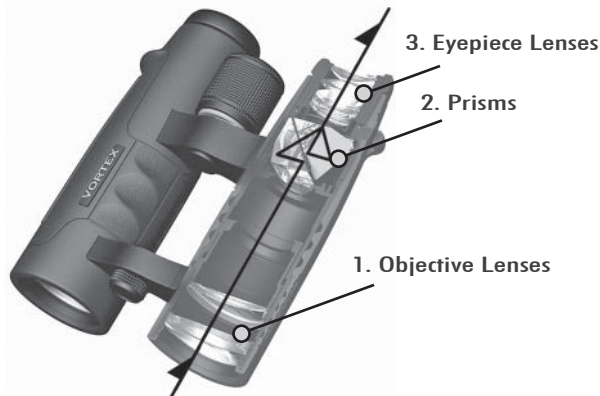

How Light Passes Through A Binocular

Adjusting Binoculars for a Custom Fit

1. Be sure the binocular is collimated.

Collimation means that the optical elements in both barrels point in the same direction. It's possible that a binocular may not be collimated because of poor construction. Mishandling can also cause the binocular to become miscollimated. Porro prism binoculars are generally more susceptible to collimation issues than roof prism binoculars.

How to test for proper collimation.

You can test a binocular for collimation by looking at a horizontal line that is about 15–20 feet away—a door frame works very well.

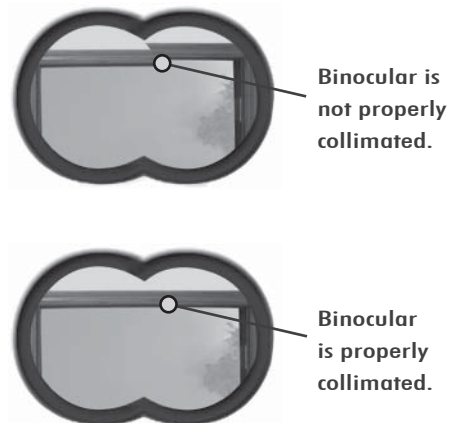

- **Put the binocular up to your eyes** and focus on the horizontal line.
- **Slowly pull the binocular away** from your eyes. The horizontal line should remain straight across the image. If the horizontal line does not remain straight, the binocular is out of collimation and needs repair.

2. Adjust the interpupillary distance.

The interpupillary distance (IPD) is the distance between the centers of the left and right eye pupil. If the IPD of the binocular does not match your eyes, adjust the position of the barrels as needed. Begin by looking through the binocular to check the image.



Rotate the binocular barrels around the hinge until your eye pupils line up with the centers of the eyepieces.

Shadows interfere with viewing.

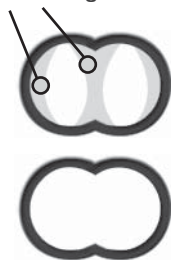

1. If the IPD is not correctly adjusted, you may see shading over part of the image.

2. When the IPD is correctly adjusted, you will see a single image without the shading.

3. Adjust the eyecups for better viewing.

Adjusting the eyecups up or down allows the user to see a full field of view. This is important for people who must wear eyeglasses or sunglasses. The two main styles of eyecup design are:

- **Flexible rubber eyecups** fold back for maximum eye relief.
- **Retractable eyecups** twist up and down for better viewing. Multi-position eyecups let the user choose the most comfortable position.



Fold-Back Eyecups

Retractable Eyecups

If you wear eyeglasses or sunglasses, rest the eyecups of the binocular against your glasses with the eyecups folded back or twisted down.



Retract eyecups when viewing with eyeglasses.

If the eyecups stay fully extended when wearing eyeglasses, images will appear as if you are looking at them through a tunnel.

If you do not wear eyeglasses or sunglasses, extend the eyecups to provide the proper distance for seeing the full field of view.



Extend eyecups to the best position when viewing without eyeglasses

If the eyecups do not stay fully extended, you may see black crescents in the field of view.

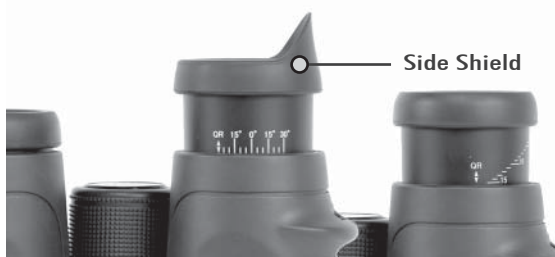

Side Shield

Some retractable eyecups, like those of the Razor, can also be interchanged with side shields. These eyecups block out stray light when viewing in bright, sunny conditions.

4. Adjust for differences in your eye strength.

Most binoculars feature a center focus wheel for general focusing as well as an adjustment ring known as the diopter. The diopter adjusts for any differences between your eyes.

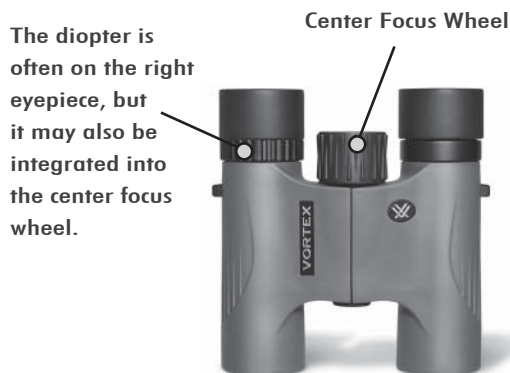

How to attain a proper focus.

The procedure for attaining proper focus has two steps. Once you have completed this process, the binocular will be set for your eyes. Make note of the diopter setting before sharing your binoculars.

- **Adjust the center focus** – Start by closing your right eye or covering the right objective lens with your hand. Focus your left eye on an object approximately 20 yards away and adjust the center focus wheel until the image is in focus.
- **Adjust the diopter** – Start by closing your left eye or covering the left objective lens with your hand. Look at the same object (from the same distance) through your right eye. Adjust the diopter until the object is in focus. From this point on, after making these adjustments, you will only need to use the center focus wheel to focus.

Note: Some diopters have a locking feature— simply unlock before moving the diopter ring.



Specifications to Disregard

Twilight Factor

Multiply the magnification and the objective lens diameter together, then find the square root of this amount—resulting value is usually between 12 and 25.

This specification gives a measure of viewing efficiency in low light. A larger number indicates brighter images in low light. The twilight factor is a dubious specification because it does not take into account the light transmission of the binocular or say anything about optical coatings or glass quality.

Relative Brightness

Square the exit pupil of the binocular.

Relative brightness measures the overall image brightness, but is misleading since different binoculars can have the same values. Both 7x35 and 10x50 binoculars have a relative brightness value of 25. In reality, a 10x50 gathers more light than a 7x35 and often presents a brighter image. Relative brightness does not take optical coatings and glass quality into account.

Features to Avoid

Focus-Free Binoculars

Advertised as focus-free, permanent-focus, or instant-focus binoculars, this design results in poor optical quality.

Ruby-Coated Lenses

Ruby coatings on the objective lenses reflect red out of the optical system and skew colors to the cool end of the spectrum. More conventional optical coatings offer increased clarity and eliminate the need for ruby-coated lenses.

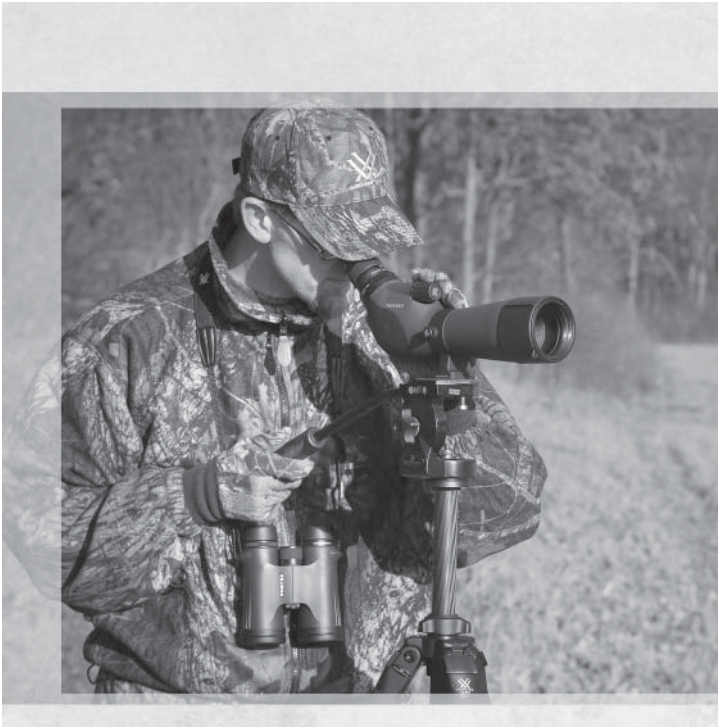

SPOTTING SCOPES

Most spotting scopes use a Porro prism design to magnify images for a rich, three-dimensional view.

What do the Numbers Mean?

Consider the example of a 20-60x80 spotting scope:

Magnification — The First Number Group

The first range of numbers (**20–60x**) indicates the magnification. Since spotting scopes feature high magnifications for long-distance viewing and large objective lenses, these optics must be mounted on a tripod.

Objective Lens Size — The Last Number

The last number (**80**) indicates the size of the objective lens in millimeters. This size affects the overall size of the spotting scope.

- **60mm spotting scopes** are fairly portable and compact, offering performance at a price that is lower than most 80mm scopes.
- **80mm spotting scopes** will be brighter than a 60mm, but are generally heavier and bulkier.

Spotting Scope Specifications

As with binoculars, you will want to consider other specifications such as the size and weight, eye relief, weatherproofing, and warranty when selecting a spotting scope. All Vortex spotting scopes are fully waterproof and fog proof.

How a Spotting Scope Works

1. Light enters the objective lens of the spotting scope.
2. Light travels through prisms that correct the image orientation in all directions.
3. Light moves through an eyepiece that magnifies the image before it reaches user's eye.

How Light Passes Through A Spotting Scope

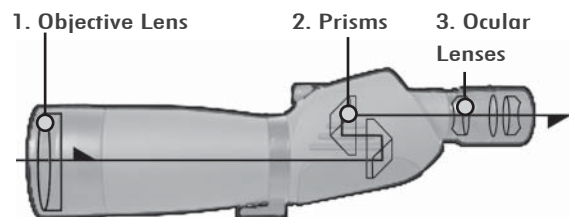

Types of Optical Glass

Some spotting scopes offer two different versions of glass: standard and high-grade. Standard optical glass offers good image quality. The high-grade scopes use premium glass that delivers heightened resolution and color. Consider selecting high-grade glass if you want the best possible image in all lighting conditions.

Although you can use a digital camera to digiscope with nearly any spotting scope, the best results come with spotting scopes using high quality optical systems.

Spotting Scope Design

Spotting scopes are used primarily for land viewing at longer distances. Manufacturers often make scopes available in two body styles. Though one design is not better than the other, each offers distinct advantages.

The Angled Spotting Scope

The angled body features an eyepiece that is set at a 45-degree angle. This style lets people of different heights share without adjusting the tripod. Because angled scopes can sit lower on a tripod, users will benefit from the added stability.

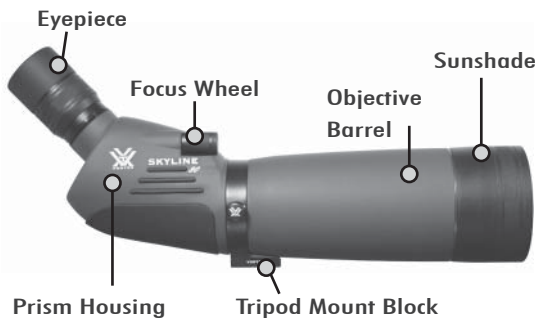

The Straight Spotting Scope

The straight body features an eyepiece in line with the objective lens. This natural line of sight works well with a car window mount.

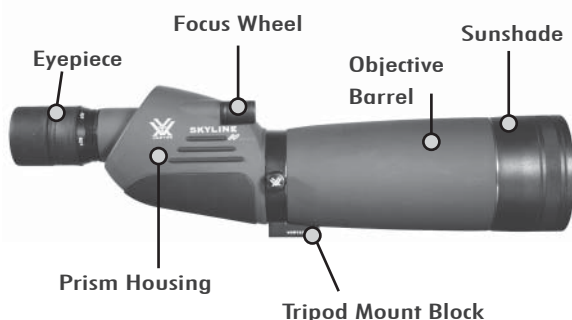

RIFLESCOPES

Understanding the Numbers

Let's consider the 2-7x32—a common size.

Magnification

The first set of numbers indicates that the magnification ranges from 2x up to 7x. Some riflescopes do not have a zoom eyepiece and use a single number to indicate a fixed magnification, as in a 2x20 scope.

Objective Lens Size

In a 2-7 x 32 configuration, the last number (32) refers to the diameter of the objective lens in millimeters. If all other things are equal, larger objectives can yield brighter images at high magnifications. This is an advantage for hunting at dusk and dawn when animals are most active.

Windage and Elevation Graduations

Graduation markings are a third type of number. Found on a rifle scope's windage and elevation adjustment knobs, these numbers are used when adjusting the rifle scope's point-of-aim. The graduations are usually scaled in minutes-of-angle (broken down into 1/4 MOA clicks) where each MOA yields about one inch of travel for every 100 yards of distance to the target.



Parallax Adjustment (More on Page 30)

A fourth type of number appears on riflescopes with parallax adjustment. The numbers are scaled in yards and marked on the objective bell for adjustable objective riflescopes, or on the left adjustment knob for side focus riflescopes.



Riflescope Anatomy

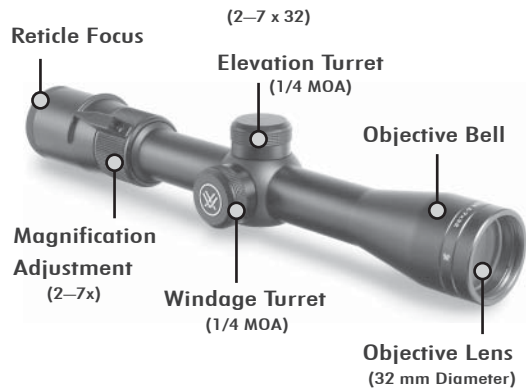

Understanding Key Specifications

Size

Riflescopes vary widely in size and weight. Some riflescopes will be short and compact, others will be longer and heavier. Choose a riflescope that matches the firearm being used.

- **A large, high-powered riflescope** may not be the best choice for a compact, lightweight rifle or slug shotgun.

- **A compact, low-powered riflescope** may not be the best choice for use with a long-distance precision rifle.

Note: Short riflescopes may have mounting problems with some rifles.

Magnification

More is not always better! Match the riflescope's magnification to the type of shooting being done.

- **Close, fast shooting** requires low-powered riflescopes with wide fields of view, such as seen through a 1.75–5x scope.
- **Long-distance hunting** requires higher magnification as provided by a 4–12x model. The power becomes more beneficial than a wide field of view.

Eye Relief

In addition to providing a decent field of view for eyeglass wearers, there must be enough eye relief to provide a space cushion that protects the eye from recoil of the firearm. Keep in mind that eye relief typically decreases as magnification increases.



Unsafe Eye Relief

Safe Eye Relief

Reticle Style

With a wide range of reticles available, knowing how you will use the reticle will help you make the right choice. Here are some of the reticles available through Vortex Optics:



- **Visually "heavier" reticles** perform better in low light—this is important for big game hunters.
- **Finer crosshairs or dots** obstruct a smaller part of the target—this is important for target and varmint hunters.
- **Extra features**, such as rangefinding or bullet drop reference points, may be helpful for long-distance shooters.

Tube Size

The one-inch tube is the size most commonly used in the United States, but you can also find 30mm or 35mm tubes on some premium scopes. The larger main tube can offer an increased elevation adjustment range—an important feature for extreme distance shooters. It is also important to know the tube size of a riflescope since mounting rings must match this same sizing.

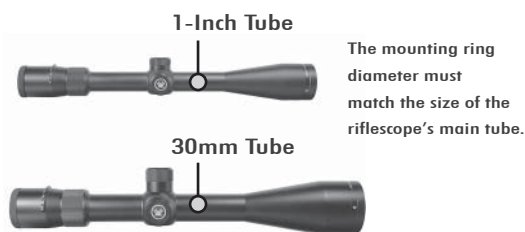

Understanding Riflescope Adjustments

Reading the Numbers on a Turret

When the riflescope is properly mounted on the rifle, the elevation turret will be located on the top side of the scope with the windage elevation turret on the right side. These turrets are most often numerically marked in minutes-of-angle (MOA), although MIL markings may also be used in some military and law enforcement applications.

MOA markings are usually subdivided in 1/4 MOA “clicks”. Therefore, it will take four clicks to move the bullet’s point-of-impact one MOA which is equivalent to:

- 1.05 inches at 100 yards
- 2.10 inches at 200 yards
- 3.15 inches at 300 yards
- and so on.

Although not as common, the subdivisions may also use markings of 1/8 MOA or 1/2 MOA.



Adjusting the Elevation – The elevation turret is positioned on the top side of the riflescope and is used for the up and down adjustment of a bullet’s point of aim.



Elevation Turret

Adjusting the Windage – The windage turret is positioned on the right side of the riflescope and is used for the left and right adjustment of the bullet’s point of aim.



Windage Turret

Note: Unlike elevation, most shooters will never adjust the windage turret after the initial sight-in is done (explained on page 33). Corrections for blowing side winds will usually be made by holding the crosshairs slightly into the wind.

Focusing Riflescopes

Getting a Sharp Reticle Image

The focus found near the eyepiece of the riflescope is only used to get a crisp, sharp reticle image—it is not used in the same way as the general focus on a binocular or spotting scope.

How to Use the Riflescope’s Reticle Focus

Start by pointing the riflescope at the sky or a white wall. Look through the scope and pay attention to how crisp and sharp the reticle image appears. Continue to rotate the reticle focus until the reticle is as sharp and crisp as possible.

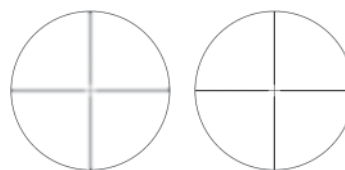

Use the reticle focus to get a sharp, crisp reticle image.

Note: This focusing should be done very quickly, otherwise the eye will try to compensate for the unfocused reticle focus.

Preventing Parallax

Use of the adjustable objective (AO) or side focus is the most misunderstood adjustment on a riflescope. Although commonly thought of simply as a focus, this misses the real intention of the adjustment which is to prevent parallax.

Parallax is the apparent shift of the reticle crosshair on a target image if the eye is not centered behind the eyepiece. The presence of parallax can result in a missed shot. Parallax is at its worst when shooting at shorter distances and higher magnifications, as in air-rifle shooting.

If an image is not focused on the reticle plane, parallax can occur.

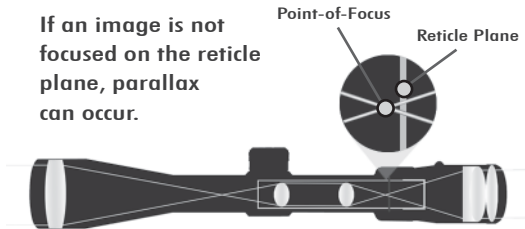

If an image is focused on the reticle plane, parallax cannot occur.

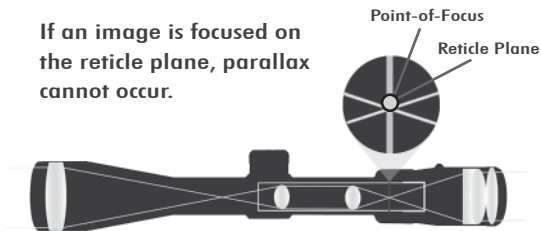

Parallax-adjustable riflescopes can move the point-of-focus so that it matches the reticle plane—preventing parallax.

Parallax can be prevented if the point-of-focus is located precisely on the reticle plane within the scope. The point-of-focus location will change in relation to the reticle plane when shooting at various distances, since the total focal length changes according to the distance to the target.



Evaluating Image Quality

What makes one riflescope cost more than another? Quality of image is one of the key differences between a top quality riflescope and a mediocre model.

Optical Glass Quality.

Higher quality riflescopes use dense optical glass that is painstakingly designed, shaped, and polished to eliminate flaws and provide better resolution. This labor-intensive process is one reason riflescopes of a higher grade cost more. For the best possible image in all lighting conditions, you'll want the highest grade of glass available.

- **Standard glass** provides good image quality.
- **Extra-low dispersion (ED or XD) and high-density (HD) glass** deliver heightened resolution and color that surpasses standard glass. Such glass is an expensive component of fine optics.

Use of Anti-reflective Coatings

As with binoculars and spotting scopes, more layers on more surfaces greatly increase the image brightness, sharpness, and contrast in low light.

Challenges to Perfect Images

Better quality lenses have greater contrast and higher resolution, less chromatic aberration, astigmatism, and distortion.



Durability of a Rifle Scope

Riflescopes must be able to handle temperature extremes, moisture, and heavy rifle recoil. While almost all riflescopes are purged of atmospheric air and are waterproof, investing in a higher quality scope will also improve the quality of construction and internal components.

Main Tube Construction.

Using a main tube machined from a single piece of aluminum, rather than a jointed two-piece tube, increases strength and resistance to moisture.

High Quality Internal Components.

Using riflescopes with high-end internal parts will provide smooth, precise adjustments in the riflescope. The premium Teflon resin bushings in the Vortex Precision Glide erector and copper/beryllium alloy springs in the Vortex Precision Force spring system are good examples of this.

Mounting a Rifle Scope to a Firearm

Rings and bases are necessary components that need to be purchased for mounting a new riflescope to a firearm.

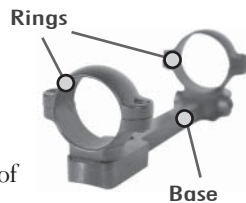

The Mounting Base.

This is a flat, grooved piece of metal that may come in one or two pieces. Bases are rarely interchangeable on firearms and must be compatible with the mounting rings used. Attach the base to the firearm's receiver via pre-drilled holes from the manufacturer.

The Mounting Rings.

There are circular pieces of metal that attach to the riflescope's main tube and lock to the base. Rings will be sized by diameter and height.

Sighting in a Rifle

After mounting the riflescope on a firearm, the process of sighting in matches the bullet's point-of-impact with the center of the reticle crosshairs.

1. Bore sighting.

This initial sight-in from a distance of 50 to 100 yards results in a rough match of the reticle crosshairs to an



object when viewed through the rifle's bore. A bore-sighted rifle will save time and ammunition at the range because the sight-in adjustments will be fairly close.

Begin bore sighting by placing the rifle on a solid rest. Remove the bolt from the rifle so you can look through the bore. Choose an object 50 to 100 yards away and view it through the bore. Adjust the windage and elevation dials until the crosshairs are centered on the same object. The rifle will then be bore-sighted and ready for the final range sight-in.

Note: Non-bolt action rifles will require the use of a mechanical bore-sighter (simply follow the manufacturer's instructions).

2. Sighting in at the range.

For this sight-in you will need to go to an outdoor shooting range. Although some hunters may prefer a longer sight-in distance, this sight-in is often done at a distance of 100 yards.

The three-shot-and-adjust process. The rifle needs to be carefully fired in a three-shot group while placed on a solid rest. Use the center of this three-shot group as a reference—adjusting windage and elevation turrets until the center of the crosshairs matches the center of the shot group.

Note: This three-shot-and-adjust process may need to be repeated several times in order to achieve the desired level of accuracy.

3. After the final range sight-in.

When shooting at distances other than the sight-in distance, account for changes in the bullet's trajectory by making up and down corrections. These corrections may be done in one of three ways, depending on which riflescope is being used.

- **Hold the crosshairs** high or low.
- **Use a bullet drop compensating reticle** such as the Vortex Dead-hold.
- **Dial adjustments** into the elevation turret.

Three ways to adjust for bullet drop:

1. Hold crosshairs high.
2. Use BDC dots.

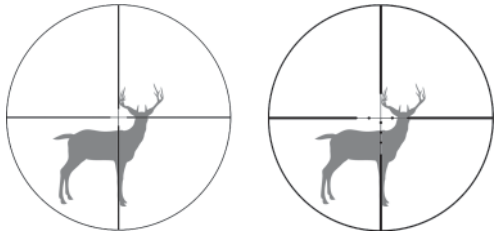

3. Compensate by adjusting the elevation knob.

Choosing a Riflescope

Depending on the type of shooting or hunting you will do, look for the most appropriate model within a riflescope series. The type of firearm should also be considered. A traditional high-powered rifle might use riflescopes such as the 3–9x, 3.5–10x, or 4–12x models. A black powder rifle or slug shotgun might run a 2–7x, 3–9x, or 1.75–5x model.

- **3–9x40 and 3.5–10x50 riflescopes** are usually meant for general big game hunting.
- **1.75–5x32 and 2–7x35 riflescopes** are for closer range brush hunting.
- **6.5–24x44 and 6.5–20x50 riflescopes** are for long-range target shooting and varmint hunting.



THE FINAL WORD

Vortex is committed to bringing you the finest optics for use in any environment—this comes from an unwavering dedication to deliver innovative products with unmatched quality, reliability, value, and performance.

For many people, this guide may only be the beginning of the journey into learning about binoculars, spotting scopes, and riflescopes. Should you have any questions or comments about this guide, please feel free to contact us.

The VIP Warranty

We build optics based on our commitment to your absolute satisfaction. That's why Vortex products are unconditionally guaranteed.

Vortex pledges this Very Important Promise to you—a Very Important Person. That's why we call it the VIP warranty. In the event that your Vortex product requires service, no matter the cause, Vortex Optics will repair or replace the product at no charge to you.



Call Vortex Optics for prompt, professional, and friendly service of products covered by the Vortex VIP warranty.



VORTEX

Vortex Optics

2120 West Greenview Drive

Middleton, WI 53562

800-426-0048

www.vortexoptics.com

info@vortexoptics.com